

DATA SHEET  
22 July 2011  
Version 1.0

TABLE OF CONTENTS

1.0	Block Diagram.....	5
2.0	Electrical Characteristics.....	6
3.0	Device Terminal Functions.....	10
4.0	Example Application Schematic.....	12
5.0	Package Dimensions.....	13
6.0	Layout Guidelines.....	14
7.0	Contact Information.....	15

## Bluetooth Audio Module

---

### DESCRIPTION:

BTM-68D is the latest generation of bluetooth Module. It provides highest level of integration

With integrated 2.4GHz radio, DSP, battery Charger, stereo codec, and antenna ready.

Mono and stereo audio applications.

BTM-68D is also ready to support the latest

Bluetooth 2.1 standard and support for secure

Simple pairing.

### FEATURES:

- ” Plug n' Play Bluetooth Solution for mono and Stereo Audio Solutions
- ” Integrated DSP, Stereo Codec , and Battery Charger
- ” Integrated Antenna
- ” Bluetooth 2.1+EDR Compliant
- ” Class II Range up to 10 Meters
- ” Temperature range from -30C to +85C
- ” Low Power Consumption
- ” Supported Bluetooth Profiles: A2DP, AVRCP, HFP, HSP
- ” Supported 5-band EQ
- ” High-quality Audio 95dB SNR on DAC Playback

### APPLICATIONS:

- ” High quality wireless stereo headsets
- ” Wireless mono headsets
- ” Wireless speakers
- ” Hands-free car kits



### 1.0 Block Diagram

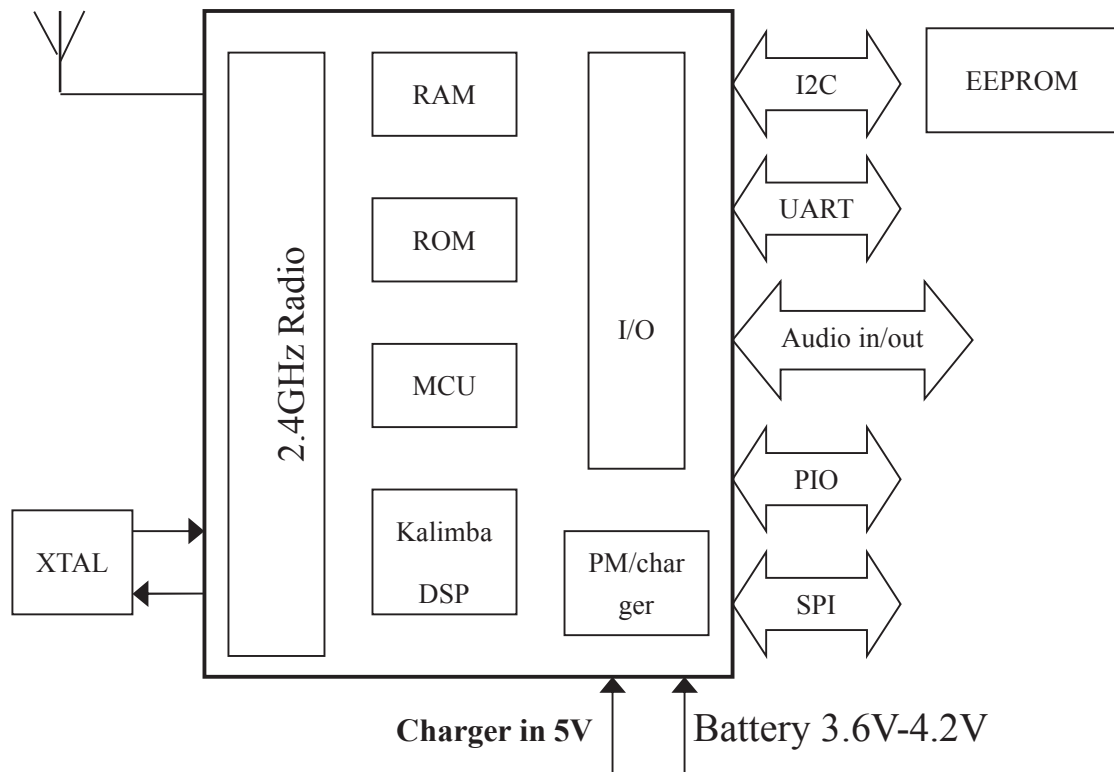

Figure 1: Block diagram of BTM-68D

**2.0 Electrical Characteristics**

**Recommended operating conditions**

	<b>Min</b>	<b>Typ</b>	<b>Max</b>	<b>Unit</b>
Operating temperature	-20	20	70	#
VDD_BAT	3.0	3.8	4.2	V
VDD_CHG	4.5	5	6.5	V
VDD_IO	1.7	1.8	1.95	V

**Table 1:**Recommended operating conditions

**Battery charger**

<b>Charger Mode(BAT_P rising to 4.2V)</b>		<b>Min</b>	<b>Typ</b>	<b>Max</b>	<b>Unit</b>
Supply current(a)		--	4.5	6	mA
Battery trickle charge current(b)		--	4	--	mA
Maximum battery fast charge current (I-CTRL = 15)(c) (d)	Headroom(e) > 0.7V	--	140	--	mA
	Headroom = 0.3V	--	120	--	mA
Minimum battery fast charge current (I-CTRL = 0)(c) (d)	Headroom > 0.7V	--	40	--	mA
	Headroom = 0.3V	--	35	--	mA

## Bluetooth Audio Module

Trickle charge voltage threshold	--	2.9	--	V
Float voltage (with correct trim value set), VFLOAT (f)	4.10	4.15	4.2	V
Float voltage trim step size(f)	--	50	--	mV
Battery charge termination current, % of fast charge current	5	10	20	%

(a) Current into VDD\_CHG does not include current delivered to battery (IVDD\_CHG - IBAT\_P)

(b)  $BAT\_P < \text{trickle charge voltage threshold}$

(c) Charge current can be set in 16 equally spaced steps

(d)  $\text{Trickle charge threshold} < BAT\_P < \text{Float voltage}$

(e) Where headroom =  $VDD\_CHG - BAT\_P$

(f) Float voltage can be adjusted in 15 steps. Trim setting is determined in production test and must be loaded into the battery charger by firmware during boot-up sequence

**Table 2:** Battery charger characteristics

## Reset

	Min	Typ	Max	Unit
$V_{TH,res}$ threshold voltage	0.65	0.85	1.50	V
$R_{IRES}$ input resistance	--	220	--	Kohm
$C_{IRES}$ input capacitance	--	220	--	nF

**Table 3:** Reset terminal characteristics

## Bluetooth Audio Module

The RESET pin is an active low reset and is internally filtered using the internal low frequency clock oscillator. A reset will be performed between 1.5 and 4.0ms following RESET being active. It is recommended that RESET be applied for a period greater than 5ms. This module has an internal reset circuitry, when this module input 5V charging voltage, Module reset once.

The capacitor discharges through 220 k resistor, which eventually deactivates the reset. Time constant of the RC circuitry is set in a way that the supply voltage is safely stabilized before the reset deactivates.

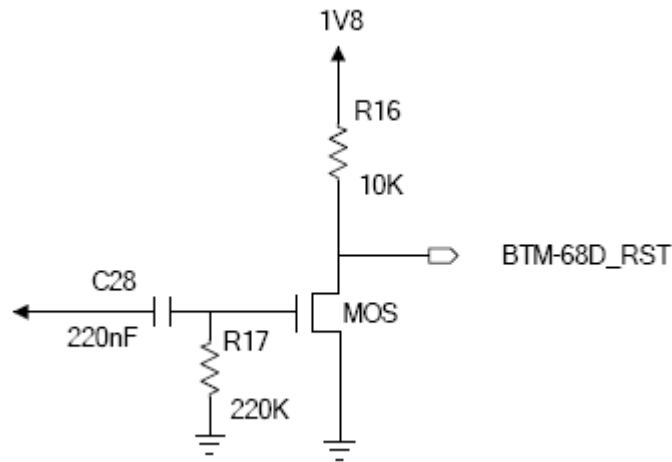
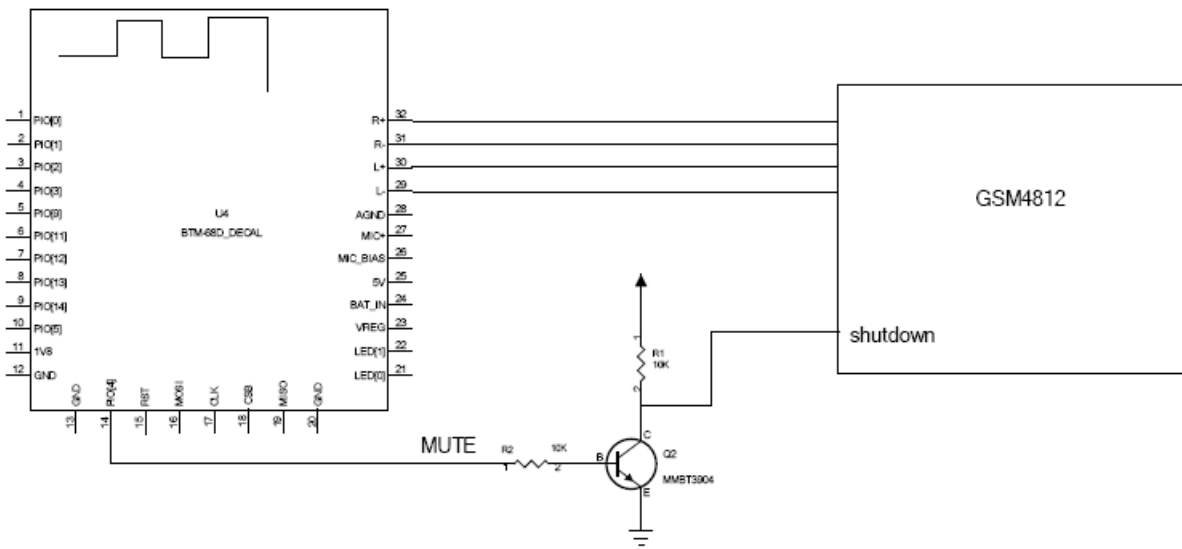

**Figure 2:** BTM-68D reset circuitry



## MUTE

BTM-68D can output a high level to control the amplifier mute. When bluetooth normal working, Module output high level to control the amplifier open. Standby, Module output low level to control the amplifier off.



**Figure 3:** BTM-68D Mute control circuitry

### 3.0 Device Terminal Functions

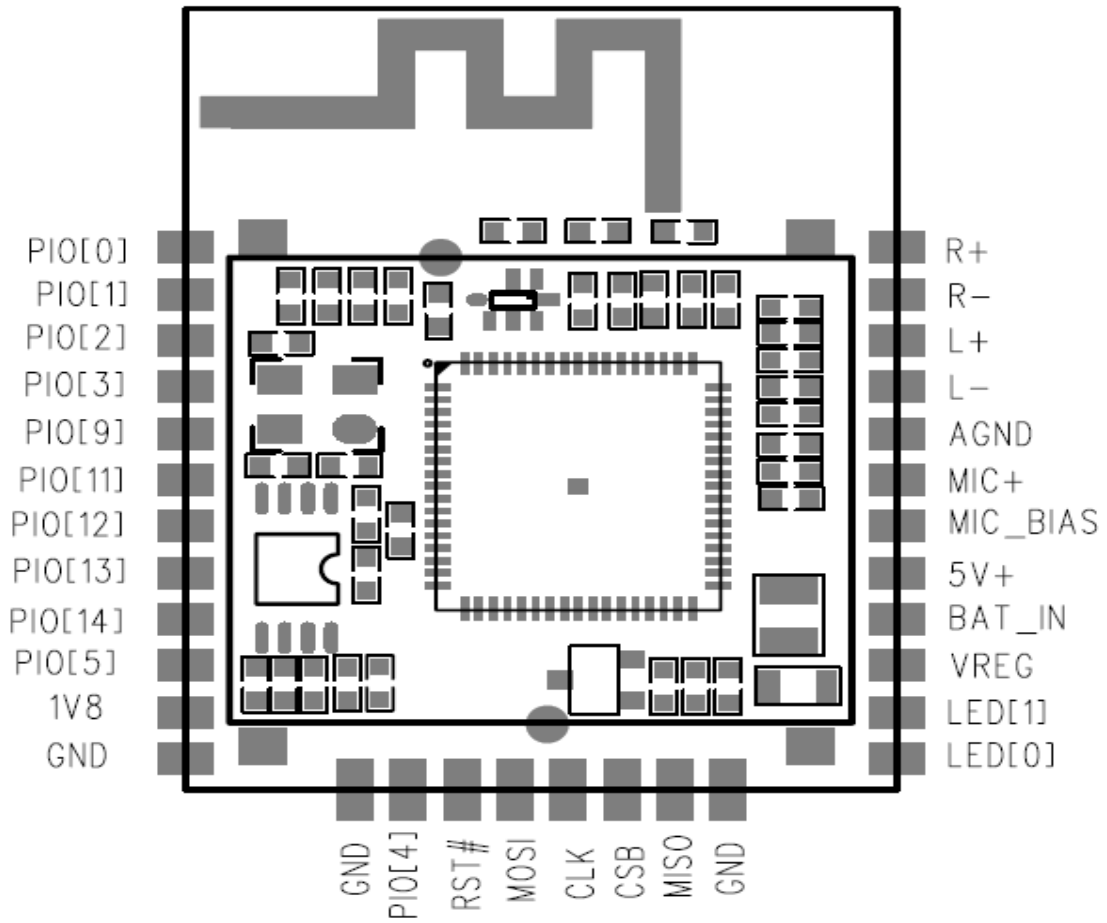

Lead	name	Function	Description
1	PIO[0]	PIO port	Programmable input/output line
2	PIO[1]	PIO port	Programmable input/output line
3	PIO[2]	PIO port	Programmable input/output line
4	PIO[3]	PIO port	Programmable input/output line
5	PIO[9]	PIO port	Programmable input/output line
6	PIO[11]	PIO port	Programmable input/output line
7	PIO[12]	PIO port	Programmable input/output line
8	PIO[13]	PIO port	Programmable input/output line
9	PIO[14]	PIO port	Programmable input/output line

**Bluetooth Audio Module**

10	PIO[5]	PIO port	Programmable input/output line
11	1V8	1.8V POWER	Positive supply for 1.8V regulated output
12	GND	GND	Ground
13	GND	GND	ground
14	PIO[4]	PIO port	Programmable input/output line
15	RST#	Reset	Logic low reset
16	MOSI	SPI interface	SPI data input
17	CLK	SPI interface	SPI Clock
18	CSB	SPI interface	Chip select for SPI
19	MISO	SPI interface	SPI data output
20	GND	GND	Ground
21	LED[0]	Status	LED driver
22	LED[1]	Status	LED driver
23	VREG	POWER ON/OFF	Module power on/off active high
24	BAT_IN	Power Input	Lithium ion/polymer battery positive terminal.
25	5V+	5V-charger	Lithium ion/polymer battery charger input
26	MIC_BIAS	MIC power	Microphone bias
27	MIC+	MIC input	Microphone input
28	AGND	AGND	Analogue ground
29	L-	L-	Speaker output, channel L negative
30	L+	L+	Speaker output, channel L positive
31	R-	R-	Speaker output, channel R negative
32	R+	R+	Speaker output, channel R positive

## **4.0 Example Application Schematic**

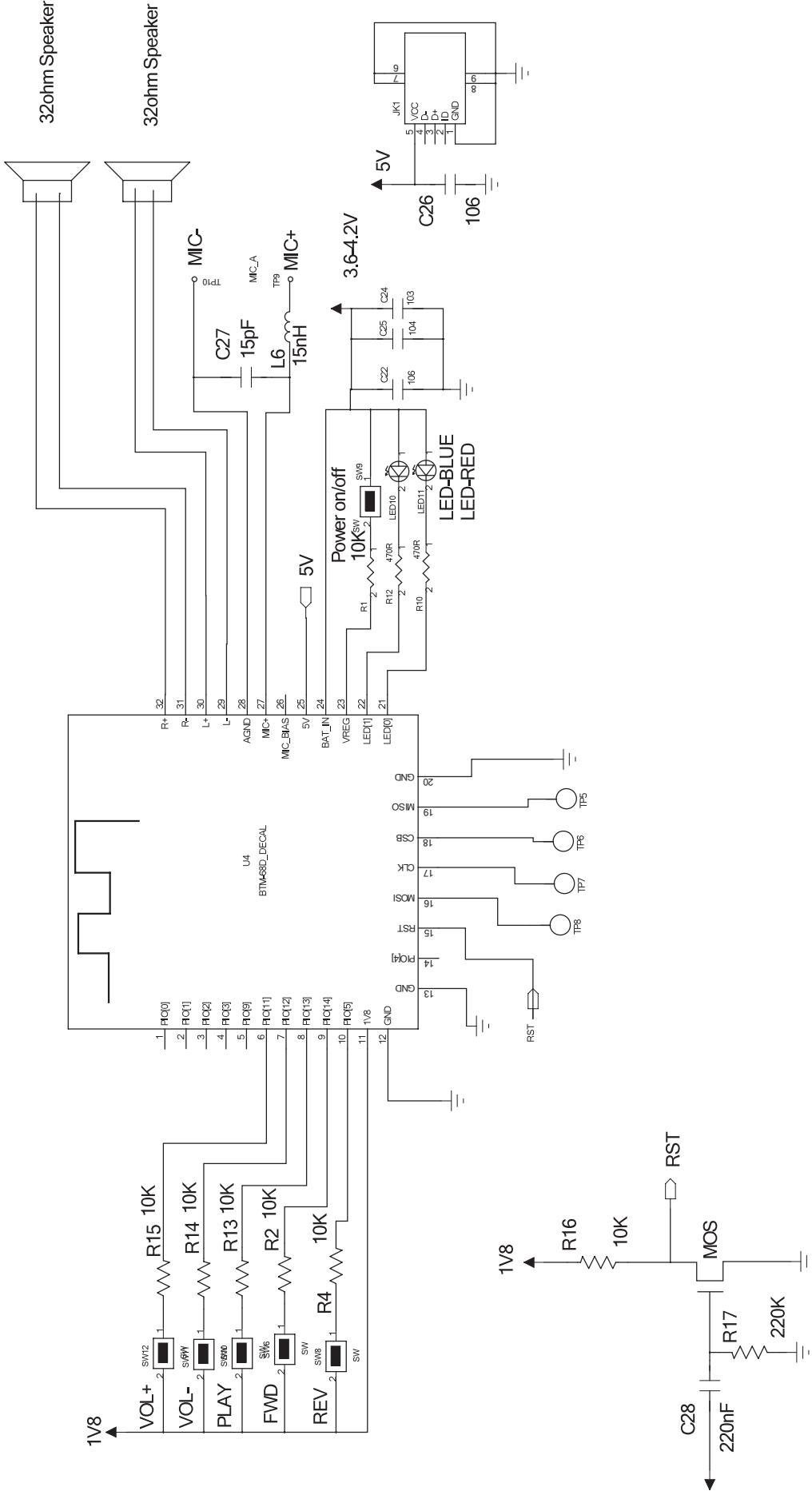

### 5.0 Package Dimensions

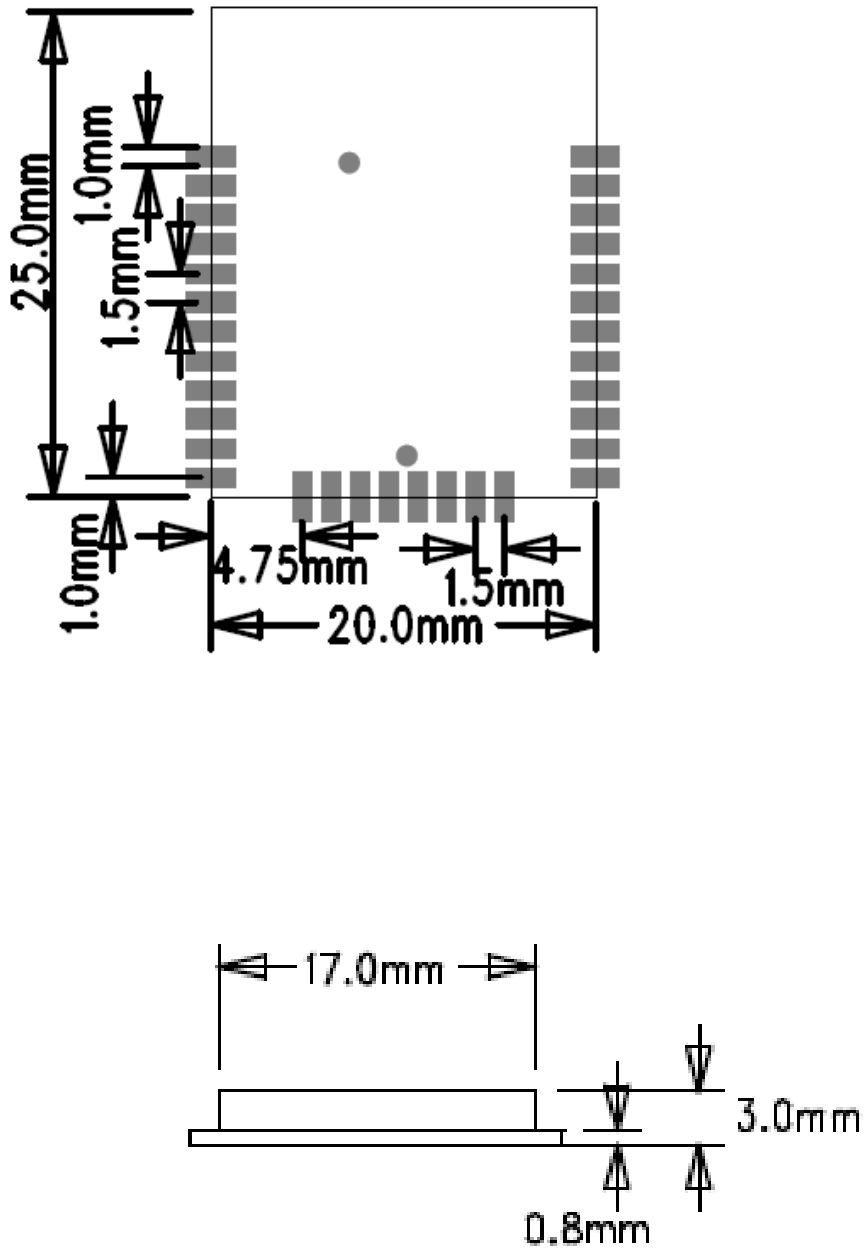

Unit: mm

## **6.0 Layout Guidelines**

### **6.0.1 Audio Layout**

Route audio lines as differential pairs. The positive and negative signals should run parallel and close to each other until they are converted to single-ended signals. Use dedicated audio ground plane for entire audio section.

### **6.0.2 Antenna Design**

Do not place GND plane or any metal directly under the antenna of module . To avoid any excess parasitic capacitance in the antenna feed line caused by the RF test pin on the bottom side of the module, the area underneath the RF test pin should also be left free from copper. Any metal in close proximity of the antenna will have an effect on the antenna performance. Thus any metal should be placed as far from the antenna as possible. The module should be placed to an edge of the PCB.

